

## **Advanced Hybrid Multi-power Station Turbine Structure for Efficient Power Generation**

Mr. Amit D. Landge

Email ID: [amitdlandge@gmail.com](mailto:amitdlandge@gmail.com)

---

### **Abstract:**

As per the technical evolution and technical trends taken into consideration so we have created a “Advanced Hybrid Multi-power Station Turbine Structure for Efficient Power Generation. This system uses an advanced savonius hybrid turbine which will rotate over multiple natural resources water force, wind power and related things having efficiency greater than aerodynamic turbine. The advancement of this turbine is that, this turbine not only rotate over multiple natural resources and artificial resources but also having capability of resources settlement into it according to multiple savonius blade structure. The advantages of this project as compared to other system is that, on one single Savonius structure unit we can able to rotate multiple power substation and other power station uses single turbine which will rotate only single generator. So power output is more efficient than that normal. This project we can able to implement at industries, factories, agricultural areas, home, airport, hill station and artificial creations. This is not a simple structure like simple turbine. This is advanced technical structure created specially taken vision over

multiple natural resources and artificial resources.

This structure having natural resources settlement and re-utilization capacity, that means this structure not only uses multiple resources i.e. wind power, water force and other but also settle them to reutilization so that this turbine rotate with more torque and able to create more output so that we can able to charge battery within minimum time.

### **Introduction:**

As per the technical evolution and latest trends taken into consideration, effectively created a new advancement in effective power generation system i.e. Advanced Hybrid Multi-power Station Turbine Structure for Efficient Power Generation. Previously till date we were aware of multiple power station and related turbines but as per future requirement of power in accordance with increasing population taken into consideration move towards a new innovation in the power generation i.e. Multi-Station power generation over single advanced Savonius turbine with hybrid structure that means this turbine having efficiency of using Artificial as well as Natural Resources for rotation i.e. air, water, stones, clay, artificial dams etc. This project uses a savonius structure which is very

advanced and having efficiency greater than other turbines also this structure is able to rotate multiple generators so that we can handle multiple power stations using that single unit. Savonius wind turbines are a type of vertical-axis wind turbine (VAWT), used for converting the force of the wind into torque on a rotating shaft. The turbine consists of a number of aerofoils, usually—but not always—vertically mounted on a rotating shaft or framework, either ground stationed or tethered in airborne systems. Now a day's power requirement is the biggest demand in the growing world. Since last decade we are using multiple turbines structure so accordingly we have succeeded to move only one generator and one station but this structure succeeded to rotate multiple generators and according having capability to move multiple stations. This Advanced Hybrid Savonius Multi-Station Structure unit uses 4 units i.e. Advanced Savonius unit, Main Bigger Arm, Sub 8 Arms, Multiple Generators Units so ultimately created Multi-station Structure. This Multi-Station Structure is the demand of developing technology.

**Block Diagram of Savonius Unit:**

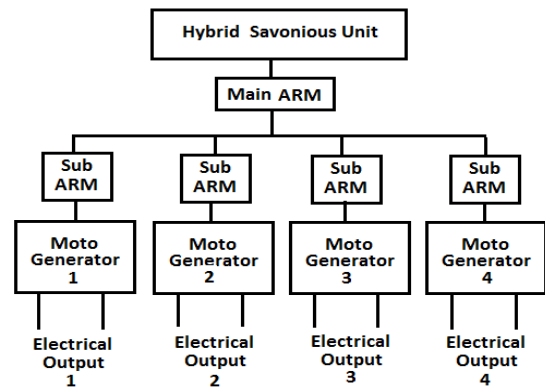
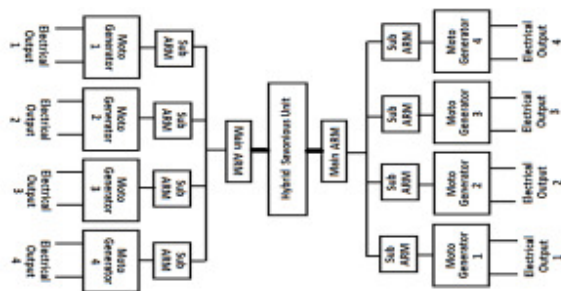

Savonius Unit with DC Transmission:

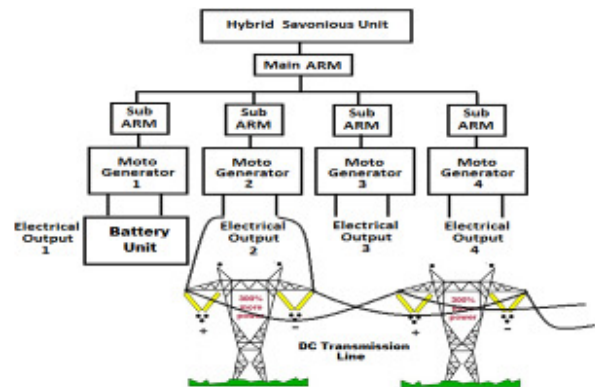

Savonius Unit With AC Transmission

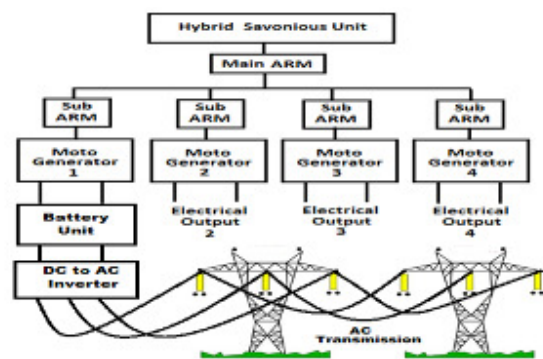

**Advanced Hybrid Savonius and arm gear based effective Mechanical Structure for Multi-Station Optimized Power Generation :**

As per the technical evolution and technical trends taken into consideration so we have created a “Advanced Hybrid Savonius and arm gear based effective Mechanical Structure for Multi-Station Optimized Power Generation. This system uses an advanced savonius hybrid turbine which will rotate over multiple natural resources water force, wind power and related things having efficiency greater than aerodynamic turbine. The advancement of this turbine is that, this turbine not only rotate over multiple natural resources and artificial resources but also having capability of resources settlement into it according to multiple savonius blade structure. The advantages of this project as compared to other system is that, on one single Savonius structure unit we can able to rotate multiple power substation and other power station uses single turbine which will rotate only single generator. So power output is more efficient than that normal. This project we can able to implement at industries, factories, agricultural areas, home, airport, hill station and artificial creations.

This is not a simple structure like simple turbine. This is advanced technical structure created specially taken vision over multiple natural resources and artificial resources.

This structure having natural resources settlement and re-utilization capacity, that means this structure not only uses multiple resources i.e. wind power, water force and other but also settle them to reutilization so that this turbine rotate with more toque and

able to create more output so that we can able to charge battery within minimum time.

This Project Consists of 4 different Units:

- ❖ Savonius Unit
- ❖ Main Arm.
- ❖ Sub Arm
- ❖ Multi-station Generator Unit

Savonius Unit:

#### Step 1: Turbine Assembly / Blades

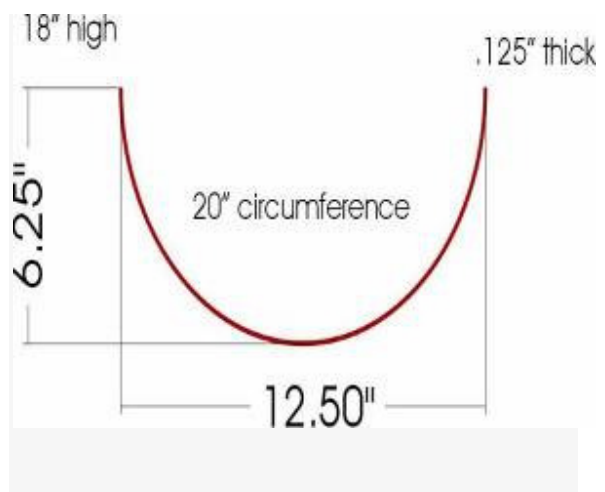

Here we will discuss the blade: material, Size, shape.

In this Project we decided to use Aluminum for Material but u can use steel, Puck Board, or even a simple 5gal pale cut into 2 or 45gal drum cut into 2, so many options you have for the blades.

The size for blade is 12.5 width, 6.25 depth, .125"thick, 20" circumference and 18" high

Savonius wind turbines are a type of vertical-axis wind turbine (VAWT), used for converting the force of the wind into torque on a rotating shaft. The turbine consists of a number of aerofoils, usually—but not always—vertically mounted on a rotating shaft or framework, either ground stationed or tethered in airborne systems.

The Savonius turbine is one of the simplest turbines. Aerodynamically, it is a drag-type device, consisting of two or three scoops. Looking down on the rotor from above, a two-scoop machine would look like an "S" shape in cross section. Because of the curvature, the scoops experience less drag when moving against the wind than when moving with the wind. The differential drag causes the Savonius turbine to spin. Because they are drag-type devices, Savonius turbines extract much less of the wind's power than other similarly-sized lift-type turbines. Much of the swept area of a Savonius rotor may be near the ground, if it has a small mount without an extended post, making the overall energy extraction less

effective due to the lower wind speeds found at lower heights.

Stepwise Creation of Assembly:

### Savonius Unit Gear Design

Main ARM:

---

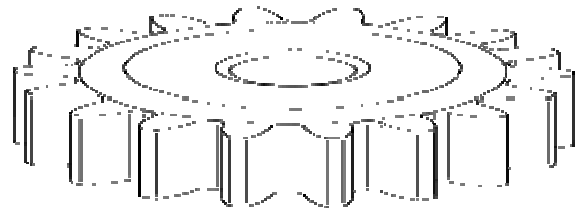

This project uses main arm having large diameter with some thickness. This main arm is link with the savonius unit, that means according to the rotation of savonius unit, the main arm rotates. the main arm is smallest in size that of savonius unit. The main arm having major gear/wheel whose RPM will be greater than that of savonius unit that means for single rotation of savonius unit the main arm rotates multiple times. This advantage which is useful to increase the RPM of main arm accordingly subarm, via savonius unit.

Sub ARM:

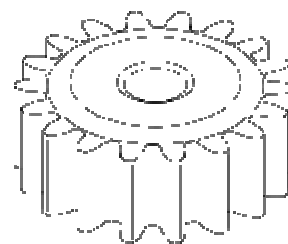

In this project, here used 4 sub arms, these 4 arm are nothing but the 4 gears which is link with main arm gear. Ultimately the rotation

savonius unit, main arm rotates and accordingly sub 4 arm rotates. The gear assembly of 4 arm are created according to increase maximum RPM stepwise from savonius unit to main arm and main arm to sub arm. The diameter thickness and teeth of gear i.e. sub arm is less than main arm and savonius unit so according we will get maximum RPM through the savonius unit and main arm and main arm o sub arm. This advance structure helps to generate maximum RPM at the sub arm. This sub arm present in a multistation structure form , so according we can able to connect multiple generator unit .

**Gear Arrangement:**

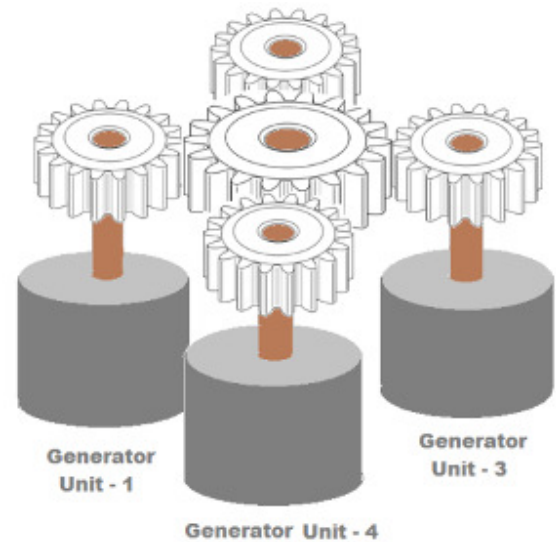
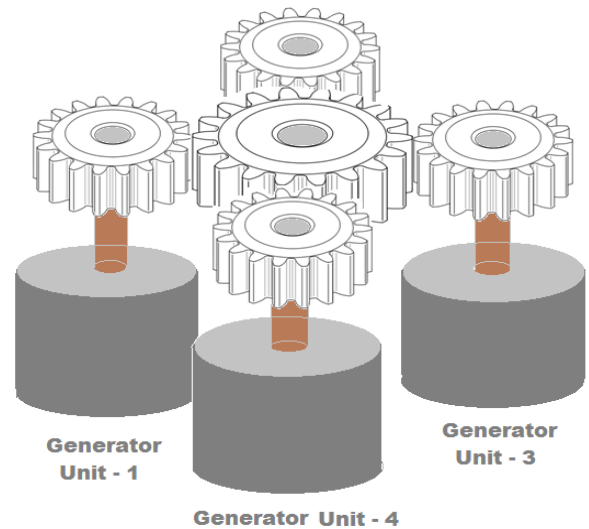
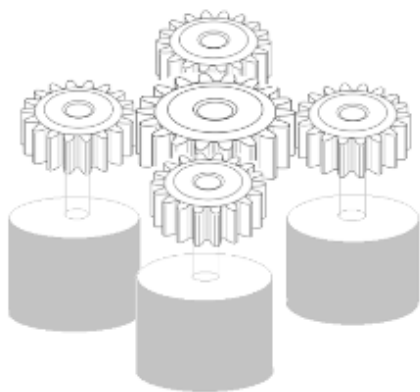

**Gear Arrangement Modified :**

---





Savonius Panel and Assembly:

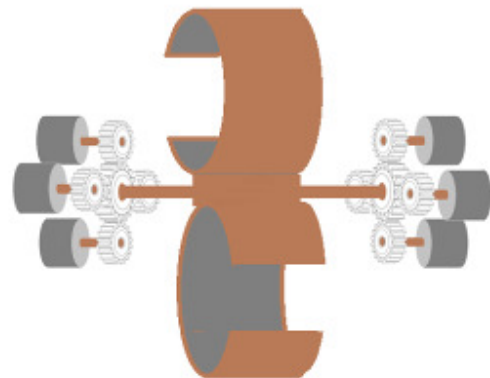
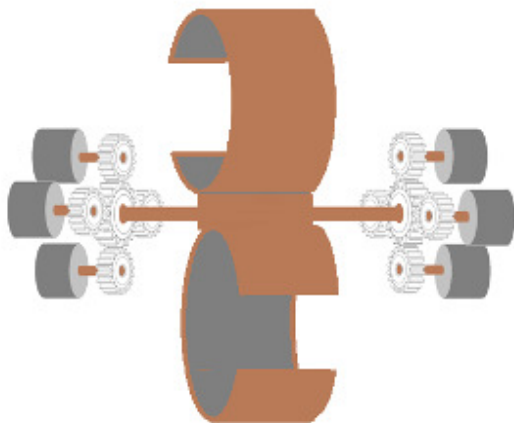

Main Savonius Assembly:

Gear Structure for Savonius Unit:

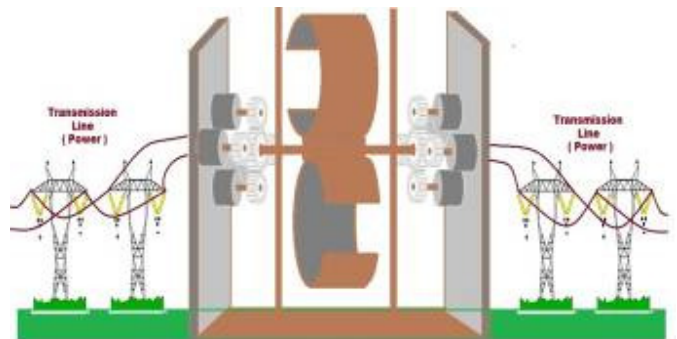
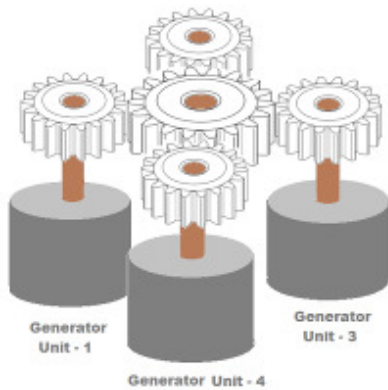

Generator Unit:

Multi-Station Structure for Savonius Unit:



This project used multistation structure that means over one savonius unit and single main arm, here used multiple sub arm and accordingly multiple generator. This assembly works from savonius unit to generator with increase in RPM form that means with minimum natural or artificial resources i.e, wind power, waterforce and etc.

The savonius structure rotates with minimum amount of energy. This rotation helps to rotate main arm with greater RPM than that of savonius turbine. The main arm

helps to rotate sub multiple arms .the RPM of sub arm is greater than main arm and accordingly the generator i.e, 4 multiple generator rotates with greater RPM .

#### Advntages

- ❖ Hybrid structure so able to rotate at any type if natural and artificial resources.
- ❖ Advanced optimized Hybrid Savonius Unit.
- ❖ Multi station Structure.
- ❖ Ability to handle multiple power station and respective load.
- ❖ Highly Efficient and optimized.
- ❖ Effective utilization with available resources.
- ❖ Artificial Resources also possible.
- ❖ Easy to create and adopt.
- ❖ Life time generation capacity.

#### Applications:

- ❖ Industrial Area to provide power to different Machinaries.
- ❖ Agricultural Area where power availability is less.
- ❖ Hills Stations generator.
- ❖ School.

- ❖ Colleges.
- ❖ Hospitals.
- ❖ Restaurants and Hotels.
- ❖ Home
- ❖ Airport.
- ❖ Railway Station.
- ❖ Villages.
- ❖ Air force and Navigation.

### Conclusion

Under the reference of our structure, for renewable energy source having 3 units i.e. savonius unit, main arm and 4 generator units. With the use of savonius unit, savonius blades not only rotates in the air i.e. on wind energy and accordingly our main arm starts to rotate which is finally provide energy to 4 different generator units, but also this blade having accessing capability is that, this blade able to rotate in minimum air and having air accessing and withstand capability rather than other different blade units. With the use of our main arm and savonius unit, our main arm starts to rotate efficiently as there is coupling between savonius unit and main arm so main arm movement is followed by savonius unit. The effective manufacturing

of main arm in such with any movement of savonius unit there is proper rotation of main arm. This structure provides efficiency to that system as compared to other system so that with the use of minimum wind energy our system start to rotates. I this project as have used 4 different generator units so our system is having capability that, it can be to handle multiple loads with multiple areas over single savonius unit and main arm so this is the main advantage of our system is that with the help of only one savonius blade structure and main arm, this system handling 4 different generators and accordingly each generator units able generates multiple generating stations so this structure capable to handle and provide sufficient power to multiple areas.

The rotation of 4 generator units is based on main arm followed by savonius unit with geared coupling. This structure i.e. single savonius with multiple generating stations over single arm not only provides efficiency to the system but also increases utility with multiple power stations. As per the result shown in table no.--- having current and voltage according to RPM followed by wing showing our system having 4 generators, combinely able to become biggest wind



power plant which will be able to handle large load. We can use this system in industrial region where large power is required also we can use this system in agricultural area where there is no availability of power so that we can be able to cover larger geographical area for power distribution. In the advent of this project if we will increase the generator capacity and large savonius unit with increase number of generators units so we can be able to create biggest power plant with optimized cost and suitable power.

#### References

- ❖ [1]Blackwell BB, Sheldahl R, Feltz LV. Wind Tunnel Performance Data for Two and Three Bucket SavoniusRotor. *Journal of Energy* ;
- ❖ [2]Le Gourieres D. *Wind Power Plants Theory and Design*; Pergamon Press Ltd, 1982.
- ❖ [3]Murat Islam on year 2010 Design and development of vertical axis Micro wind Turbine.
- ❖ [4].Renewable energy sources by G.D. RAI,chapter:- Wind energy.
- ❖ [5]The Encyclopedia of Alternative Energy and Sustainable Living. 2008. Wind
- ❖ [6]TurbineBlades.URL:[http://www.daviddarling.info/encyclopedia/B/AE\\_blades.html](http://www.daviddarling.info/encyclopedia/B/AE_blades.html) (cited January 1, 2008)
- ❖ [7]Abramovich, H. 1987. Vertical Axis Wind Turbines: A Survey And Bibliography.
- ❖ [8]Wind Engineering.Vol 11, No 6, pp 334-343.
- ❖ [9]World Wind Energy Association - Home.29Apr.2009<[http://www.wwindea.org/home/images/stories/worldwindenergyreport2008\\_s.pdf](http://www.wwindea.org/home/images/stories/worldwindenergyreport2008_s.pdf)>
- ❖ [10]World Wind Energy Association - Home.29Apr.2009<[http://www.wwindea.org/home/images/stories/worldwindenergyreport2008\\_s.pdf](http://www.wwindea.org/home/images/stories/worldwindenergyreport2008_s.pdf)>
- ❖ [11]"Installed Wind Capacity Surged 45% in 2007: AWEA Market Report." American
- ❖ Wind Energy Association. 29 Apr. 2009
- ❖ [12]"Wind and Hydropower Technologies Program: How Wind Turbines Work." EERE:
- ❖ EERE Server Maintenance. 29 Apr. 2009<[http://www1.eere.energy.gov/windandhydro/wind\\_how.html](http://www1.eere.energy.gov/windandhydro/wind_how.html)>.
- ❖ [13]"What is Magnetic Levitation?" The TechFAQ.29Apr.2009<<http://www.techfaq.com/magneticlevitation.shtml>>

- ❖ [14]“Magnet Design”. 2000 Magnet Sales & Manufacturing Company, Inc.<<http://www.magnetsales.com/Design/DesignG.htm>>.
- ❖ [15]Wikip.<<http://www.wikipedia.com>>.
- ❖ Mohan, Ned. Electric Drives An Integrative Approach. Null: Mnpere, 2004.