

# Embedded System for Control of Traffic Rule Violations

K.S. Chandekar<sup>1</sup> and Y.B. Gawali<sup>2</sup>

<sup>1</sup>Lecturer, Abha Gaikwad Patil College of Engineering, Nagpur,

<sup>2</sup>Lecturer G. H. Raisoni Polytechnic, Nagpur

kchandekar1982@gmail.com,yogesh.gawali@raisoni.net

**ABSTRACT:** With the increase in amount of traffic, traffic rule violation has become a common affair which leads to road accident causing small injuries, permanent disability or even loss of life. Also excess speed of vehicle and trespassing of traffic signals is another problem which leads to the same. Here we are proposing a system which can be used to regulate the trespassing of traffic signal and over speed violation within the city limit and reducing the damage to human life. Here the system makes use of ARM processor along with sensors and electromechanical system to detect and regulate the speed violation within the city limit and trespassing of traffic signals. Also the system generates warning signal for the user along with sending an traffic rule violation message to the RTO centre to help the RTO officers to take legal action against by means of cancelling driving license for the violation of traffic rules.

**KEYWORDS:** User, Vehicle, RTO, ARM Processor

## I. INTRODUCTION

With the increase amount of traffic rules violation and excess speed of vehicle there is an increase of road accident with many getting seriously injured with permanent disabilities in some cases. The present system of controlling of traffic in our country where people are habitual of breaking the traffic rule it is not so efficient. Even deploying advance system to detect the violation such as CCTV camera based monitoring is a costly affair. Here I am representing a remedy for the problem of violation of traffic rules by the use of an embedded technology which will be a good alternative for the present system for the control of traffic rule violation which is also cost effective. The idea behind this is to use a GSM based wireless network for carrying out the all the operations. Here the system with the help of RF sensors in the vehicle will detect the violation of traffic rule within the city limit and will send a traffic rule violation message consisting of the vehicle registration number, time and date of violation to an RTO office through GSM link. The

receiver at the RTO will collect the information with which the RTO will send a ticket to the respective person violating the rule.

Mean while the speed sensor in the vehicle will monitor the speed of the vehicle and if the speed limit exceeds the certain level it will generate warning for reducing the speed. If no action is taken by the driver after a certain amount of time the system will again send the speed violation message to the RTO office and will start taking corrective measures to reduce the vehicle speed.

On the other hand if the vehicle moves out of the city limit a transmitter located outside the city limits will transmit an message to deactivate the rule violation functionality of the system in the vehicle and the vehicle can proceed in the usual way.

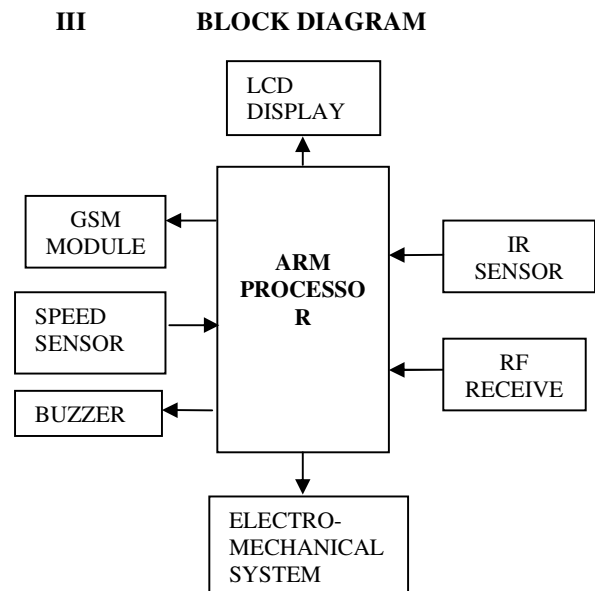
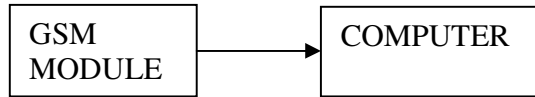

Fig.1 VEHICLE TRANSMITTER MODULE.



**Fig 2. RECEIVER MODULE**

Here as shown in fig.1 the transmitter module consists of an ARM processor which controls all the functions of the system. RF sensor is used to recognize the RF signal transmitted by the RF transmitter located at the city limit. Laser sensor is used to detect the traffic violation. Speed sensor is used to sense the speed of the vehicle within the city limit. The GSM module is used to send the violation messages to the central governing authority RTO. The fuel limiter consists of a mechanical arrangement to control the flow of fuel with the help solenoid valve.

Similarly the receiver module as shown in fig.2 consists of an GSM module to receive the message send by the transmitter module and an computer system to display message details and create an database for every message received.

### III METHODOLOGY

As the vehicle enters the city limit the RF TAG sensor detects the RF signals coming from the RF transmitter located outside the city limit and sends an control signal to the ARM processor which switches the system in city driving mode and acknowledges the driver of the same by ringing the buzzer and displaying the respective message on the LCD display.

With the city mode on the system continuously monitors the speed of the vehicle with the help of speed sensor which generates an analog value as an input to ARM processor. The ARM processor processes this analog input and determines the speed of the vehicle. As the vehicle speed exceeds the threshold value system generates warning through the buzzer and displaying the speed violation message on LCD display. System generates same warning for first three speed violation but on forth violation system along with generating warning also sends a speed violation message to the RTO authority.

While monitoring the speed for vehicle speed exceeds the threshold value the system will limit the speed within the threshold value with the help of circuit

breaker assembly which breaks the supply to sparkplug ultimately slow down the vehicle speed below threshold value and restores the sparkplug supply once the speed is within threshold limit.

On the other side being in city limit when the vehicle reaches the city square with red (stop) signal for user the RF sensor will receive a stop signal from the RF transmitter which will be activated with red signal located at the square and synchronized with the traffic signal. On receiving the stop signal system will activate the electromechanical system which will stop the vehicle and prevent the trespassing of red signal. If the user tries to violate the red signal the sensor mounted on vehicle senses the violation generates signal as an input to the ARM processor. The ARM processor recognizes this signal and generates and warning signal with the help of buzzer and displaying the respective message on the LCD screen. The system will generate same warning and will send a traffic rule violation message to the RTO authority.

Once the user moves out of the city limit system will receive another RF transmitters signal located at the city limit. Due to this the city driving mode of the system will be deactivated and user can ride the vehicle usual manner.

The receiver module receives the violation message send by the transmitter module and displays the number, time, date and the type of violation content in the message. It also creates the database of the information content in the message. With the help of this database the RTO authority can take any action against the user as fit by the law.

### IV SIGNIFICANCE

With the increase in the amount of loss of life due to drunk and drive and over speed violation this system can be helpful for reducing the death toll to a greater extent. Also the inconvenience caused due to trespassing of the traffic signals can be controlled on the basis of the corrective and legal action taken by the RTO authority based on the data received through the GSM link.

### V OBJECTIVE

The objective is to provide alternate, accurate and cost effective system for controlling traffic rule violation for

reducing the amount of road accident and thus ensuring the road safety.

#### **REFERENCES**

- [1] Vijay Deep Bhatt, Sachin Singh Khati, Diwesh Pandey, Hem Chandra Pant “Wireless traffic system with speed control” IEEE 2010 proceeding Volume1 978-1-4244-5586-7/10.
- [2]R.S. Burton, N. C. Thomas “Wireless Communication to Road Users and Within Urban Traffic Management and Control System” Road Transport Information and Control, Conference Publication No.4720 IEEE 2000.
- [3] Malik Tubaishat, Qi Qi, Yi Shang, Hongchi Shi “Wireless Sensor-Based Traffic Light Control” publication in the IEEE CCNC 2008 proceedings.
- [4] Uroš Puca, Andreja Abinab, Anton Jeglič, Pavel Cevcd and Aleksander Zidanške. Advanced electromagnetic sensors for sustainable monitoring of industrial processes Proceedings of ECOS 2012- The 25<sup>th</sup> International Conference on Efficiency, Cost, Optimization, Simulation and Environmental Impact of Energy Systems. June 26-29, 2012, Perugia, Italy.
- [5] Francesco Delli Priscoli, Alberto Isidori “A Control-Engineering Approach to Traffic Control in Wireless Networks” Proceedings of the 41st IEEE Conference on Decision and Control Las Vegas, Nevada USA, December 2007.
- [6]Faisal A. Al-Nasser , Hosam Rowaihy “Simulation of Dynamic Traffic Control System Based on Wireless Sensor Network” 2011 IEEE Symposium on Computers & Informatics.