

Design a Dual-band Microstrip Antenna for Wireless (GPS) Application

¹MS.A.J.UPADHYAY, ²PROF. P. J. BRAHMBHATT

¹M.E.[Communication Engg] Student, Department Of Electronics & communication
Engineering, L.D. College Of Engineering [GTU], Ahmedabad

²Ass. Professor , Department Of Electronics & communication Engineering,
L.D. College Of Engineering[GTU] , Ahmedabad

amee4484@yahoo.co.in, pinkybrahmbhatt@gmail.com

ABSTRACT: A dual-band circularly polarized stacked microstrip antenna for precise global positioning system (GPS) applications is proposed and experimentally studied. The microstrip antenna for dual-frequency circular polarization (CP) can be achieved without an air layer between the two stacked patches. The top patch has a pair of truncated square corners, and the bottom patch has a pair of truncated isosceles triangular corners. The antenna design for dual-band GPS at 1575 MHz and 1227 MHz is demonstrated here. Details of the obtained dual-band CP performances are presented and discussed.

I: INTRODUCTION

A Microstrip patch antenna is a type of antenna that offers a low profile, i.e. thin and easy manufacturability, which provides a great advantage over traditional antennas. Patch antennas are planar antennas used in wireless links and other microwave applications. The Microstrip technique is a planar technique used to produce lines conveying signals and antennas coupling such lines and radiated waves. It uses conductive strips and/or patches formed on the top surface of a thin dielectric substrate separating them from a conductive layer on the bottom surface of the substrate and constituting a ground for the line or antenna. A patch is typically wider than a strip and its shape and dimensions are important features of the antenna. Microstrip patch antennas are attractive due to their compact structure. Light weight due to the absence of heavy metal stamped or machined parts, and low manufacturing cost using printed circuit technology. They also provide low profiles, conformity to surfaces and direct integration with microwave circuitry. Consequently, Microstrip patch antennas are used widely in antenna arrays. Microstrip antennas require less space, are simpler and less expensive to manufacture, and are more compatible than reflector antennas with printed-circuit technology.

II: ABOUT GLOBAL POSITIONING SYSTEM (GPS)

Global Positioning System (GPS) technology has been widely used as a navigation system to determine the locations, mapping, tracking devices, and surveying. In terms of public used, GPS receiver requires compact, lightweight, low power, low cost, high reliability and with mobility capability . For our

daily life, GPS also provide us with position, timing, and velocity information that can implement in many applications. GPS is a dual system. That is, it's providing separate services for civil and military users. GPS was initially developed for military uses, but has since been adopted for both civil and military users. With the rapid growth of the wireless communication, the uses of GPS functionalities are becoming more ubiquitous. Handheld terminals with GPS functionality are becoming common. Mobile phones, laptop computers, and Personal Digital Assistant (PDA) may also have GPS functionality. So, in terms of public use, GPS receiver requires compact, lightweight, low power, low cost high reliability and with mobility capability. Furthermore, in order to satisfy the demanded precision and reliability, a high performance GPS antenna must be capable to operate at two or more frequencies at the same time.

III: ANTENNA DESIGN

The geometry proposed for the dual band circularly polarized (CP) SSAEP antenna. Two shorted elliptical annular patches are concentrically printed on two stacked substrates separated by an air-gap. For simplicity, both the substrates have been selected to have the same dielectric constant and height. The inner border of the antenna, in common with the two rings, is shorted to the ground plane. The stacked antenna is fed using a single coaxial probe electrically connected to the upper ring through a clearance hole of radius mm in the lower patch. The position of the feed is defined in terms of polar coordinates, and with respect to the antenna center. In the proposed antenna design, the top patch is used as a resonant radiator for 1575 MHz, and the bottom

patch for 1227 MHz. Due to different truncated corner shapes in the two patches, the current distribution of the top patch differs from that of the bottom patch. It is expected to have less coupling effect between the top and bottom patches when the proposed antenna is excited at 1227 MHz or 1575 MHz. Then, the required CP performances of the proposed antenna without an air layer between the two patches can be more easily achieved at both 1227 MHz and 1575 MHz CP frequencies. The 3-dB beam width of the proposed antenna studied here is larger than that of the previous studied antenna with an air layer. As the radiation patterns shown in the measured front to back ratio of the proposed antenna with a 10cm×10cm ground plane is around -20 dB.

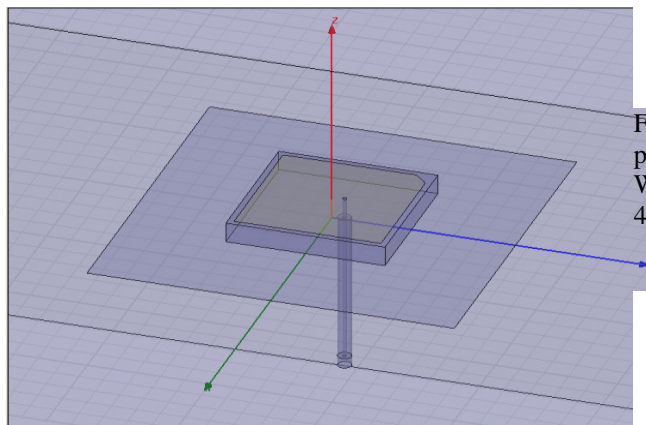

Fig.1 Antenna Design

IV: RESULTS AND DISCUSSION

To produce dual-band at 1227 MHz and 1575 MHz, the side lengths of the top and bottom patches studied here are fixed to be 47.2 mm and 57.8 mm, respectively. The measured and simulated results of the return loss for the proposed dual-band microstrip antenna. It can be seen that the experimental result is in good agreement with the simulation obtained from the CST software. By choosing the proper feed position ($F = 18.5$ mm) in the y axis, L1 and L2 GPS bands of the proposed single-feed antenna can both be excited with good impedance matching. The obtained impedance bandwidths of 10-dB return loss for the L1 and L2 bands are 45 MHz (or 2.9%) and 46 MHz (or 3.7%), respectively. It is also observed that the side length of the top patch of the proposed antenna is 0.8 times that (60 mm) of the previous studied antenna with an air layer. This is due to the fact that the air layer lowers the effective relative permittivity of the substrate and makes the resonant electric length longer.

The 3-dB beam width of the proposed antenna studied here is larger than that of the previous studied antenna with an air layer. The measured front to back ratio of the proposed antenna with a 10cm×10cm ground plane is around -20 dB.

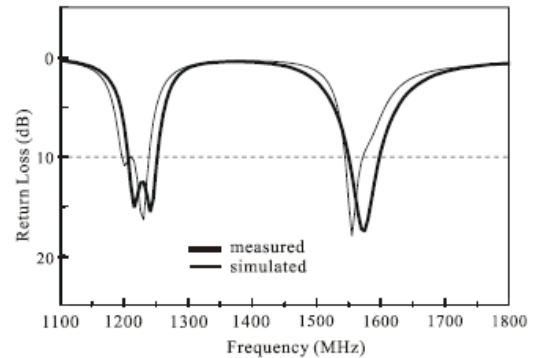

Fig. 2 Measured and simulated return loss for the proposed dual-band antenna; $\epsilon_r = 4.4$, $h = 1.6$ mm, $W_1 = 57.8$ mm, $D_1 = 6.7$ mm, $W_2 = 47.2$ mm, $D_2 = 4.4$ mm, $F = 18.5$ mm.

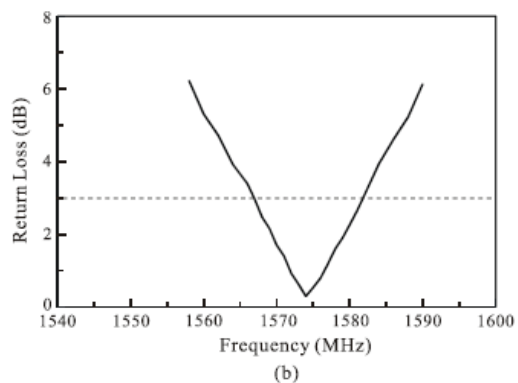
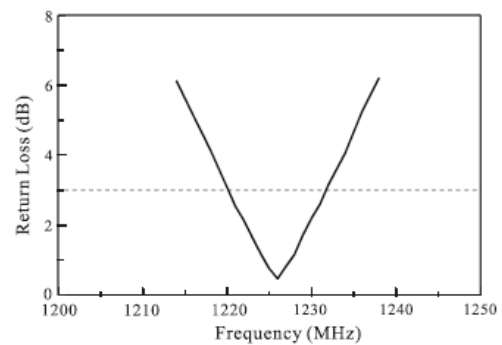

Fig. 3 Measured axial ratio against frequency; antenna parameters are given in Figure 2. (a) L2 band. (b) L1 band

V: CONCLUSION

A single-feed dual-band stacked microstrip antenna for precise GPS operations at 1227 and 1575 MHz has been presented and investigated. In the proposed antenna design, the dual-frequency CP operation is achieved by using two stacked patches with truncated square corners or isosceles triangular corners. Compared with the conventional dual-band stacked microstrip antennas with an air layer or two substrate materials, the present proposed antenna has advantages of low cost and easy fabrication. In this study, dual-frequency CP performances of the proposed antenna, such as impedance bandwidths, axial ratio, and radiation patterns, are demonstrated. Experimental results agree well with the simulated results obtained from the CST software.

REFERENCES

- [1] L. Boccia, G. Amendola, and G. Di Massa, "A dual frequency microstrip patch antenna for high-precision GPS applications," *IEEE Antennas Wireless Propag. Lett.*, vol. 3, pp. 157-160, 2004.
- [2] Shyh-Yeong Ke, "A Dual-band Microstrip Antenna for Precise GPS Applications"
- [3] C. Vishnu, Rahul Rana, "Design of Rectangular Microstrip Patch Antenna", IEEE, National Institute of Technology, Rourkela, 2009.
- [4] C.A. Balanis, *Antenna Theory*, Wiley Inter science, 3rd Edition.
- [5] B.T.P.Madhav, K.Praveen Kumar, J. Doondi Kumar, "Microstrip GPS Patch Ceramic Antenna", *International Journal of Emerging Technology and Advanced Engineering* Website: www.ijetae.com (ISSN 2250-2459, Volume 2, Issue 4, April 2012).
- [6] C. Vishnu, Rahul Rana, "*Design of Rectangular Microstrip Patch Antenna*", IEEE, National Institute of Technology, Rourkela, 2009.
- [10] Keith R. Carver, JAMES w. MINK, "*Microstrip Antenna Technology*" *IEEE Transaction on Antenna and Propagation* VOL. "-29, NO. 1, JANUARY 2009.
- [11] B.T.P.Madhav, K.Praveen Kumar, J. Doondi Kumar, "*Microstrip GPS Patch Ceramic Antenna*", *International Journal of Emerging Technology and Advanced Engineering* Website: www.ijetae.com (ISSN 2250-2459, Volume 2, Issue 4, April 2012).