

## MULTI AXIS-NOZZLE FIRE EXTINGUISHER

HARDIK MEHTA<sup>1</sup>, RAHUL CHANDRAN<sup>2</sup>, SURAJ MOHITE<sup>3</sup>, AJINKYA MANE<sup>4</sup>

<sup>1, 2, 3, 4</sup> Department of Mechanical Engineering,  
SVPM College of Engineering, Malegaon (Bk), Pune University,  
Baramati, Pune, India.

Surajmohite8188@gmail.com

**ABSTRACT :** *The development of water mist fire suppression technology has made substantial progress over the last decade. Water mist based techniques are becoming popular but the fire extinguishment products call for high initial investment. There exists a need to develop cost effective water mist generation techniques appropriate for fire suppression. A standard portable water-CO<sub>2</sub> fire extinguisher nozzle is selected for study with an application density of 1.0 l/min/m<sup>2</sup>. A multi-jet nozzle with opposed jet configuration is developed to get improved spray characteristics. Droplet Sauter Mean Diameters (SMD) were empirically calculated using correlations available in the literature. The spray developed has resulted in droplets with SMD in the range of 0.3 – 0.4 mm as calculated from correlations and confirmed using experimental measurements. A thrust-vectoring axisymmetric (VA) nozzle and a spherical convergent ap (SCF) thrust-vectoring nozzle were tested along with a baseline nonvectoring axisymmetric (NVA) nozzle in the Langley 16-Foot Transonic Tunnel at Mach numbers from 0 to 1.28 and nozzle pressure ratios from 1 to 8. Test parameters included geometric yaw vector angle and unvectored divergent ap length. No pitch vectoring was studied. Nozzle drag, thrust minus drag, yaw thrust vector angle, discharge coefficient, and static thrust performance were measured and analyzed, as well as external static pressure distributions.*

**KEY WORDS :** Atomization, fire suppression, portable water extinguishers, spray nozzles, water spray

### 1. Introduction

Recent and earlier fire incidents have clearly demonstrated some of the major shortcomings in our firefighting capabilities along the length and breadth of the country. The recent fire incident in a hospital in India has added another dangerous possibility and dimensions to fire accident. We need to have a serious look at the capabilities of our fire services in this context. If the tele-therapy machine in the hospital had been damaged, the incident would have assumed a completely different tone and escalated into an even worse tragedy. The Mayapuri incident in our country is a very recent example of what can happen if a radiological device gets damaged. We need to examine whether our fire services have the capability to respond in a fire incident when radiological equipment has got damaged. Are the fire services trained and equipped to respond or even capable to contain and restrict the dangers till other experts arrive? There is more than an urgent need to ensure that the fire services are well equipped and trained to respond to all possible vulnerabilities resulting out of fire accidents. The instructions are given in NDMA guidelines for nuclear and radiological emergencies must be followed for management of such type of incidents and must mandatorily be a part of the firemen training as hospitals having radiological machines are spread throughout our country. Unless there is a conscious and planned effort in all the states, the fire fighting

capabilities of the country are not likely to improve and an unacceptable number of deaths along with huge loss of property will continue to occur. To prevent such unwarranted deaths and loss of property there is an urgent need therefore, to start a planned and determined move towards revamping the fire services in India. Water is the most cost effective reagent for fire extinguishment. Water in the form of jets/sprays is used for fire suppression. Water dispensation at an optimal rate is essential to improve effectiveness of utilization and also protect the fire affected regions from the ill effects of water inundation in the post fire scenario. Several studies exist in the literature aimed at improving the utilization efficiency of water during fire suppression. Breaking up water jets into finer particles improves surface area available for heat absorption but smaller particle mass reduces penetration of water into fire. Mist based extinguishers are available in the market which claim lower water consumption but they are prohibitively expensive and there for their availability for use is restricted. Even to this day, the flow rates employed in Class – A fire extinguishers available in the market utilize large application densities (>1l/min/m<sup>2</sup>) to ensure effectiveness in extinguishment. Therefore, there exists a scope for improvement in water utilization effectiveness of fire extinguishers.

Standard issue portable water CO<sub>2</sub> fire extinguisher of 9l volume is selected for the

present study. Water jet nozzle is replaced with a multi-jet opposed configuration.

**2. SPHERICAL MULTI-NOZZLE FIRE EXTINGUISHER:**

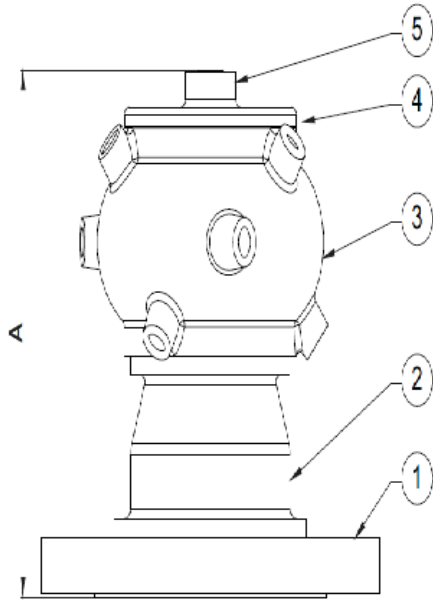

Fig: 2-D Model Of Multi-Nozzle Fire Extinguisher

**2.1 Material Specification:**

SR. NO.	DESCRIPTI ON	SPECI- FICATIO N
1	FLANGE	ASTM A105
2	HOUSING	ASTM B62
3	REVOLVING ROUND HEAD	ASTM B62
4	BALL	S.S.
5	CAP	ASTM B62

**2.2 DESCRIPTION :**

The Revolving Nozzles are generally used to protect the fixed roof storage tank top and for many other applications. The nozzle starts rotating at 2 bar water pressure. The nozzle is of bronze construction with stainless steel ball bearing. It covers about 10 diameters area at 2 Bar. The main pipeline strainer as per NFPA – 15 is required for system utilizing nozzles orifice diameter less than 9.5 mm (3/8 inch).

The Revolving Nozzle must be handled with due care. For best results, the storage as well as any further shipment be

made in original packing only. The revolving nozzle which is visibly damaged should not be installed. It is recommended that water spray system be inspected regularly by authorized technical personnel. The nozzle must be checked for atmospheric effects, external and internal obstruction, blockage if any. The nozzle should be cleaned or replaced if required. The system must be operated with optimum water flow at least four times in a year or as per the provisions of NFPA / TAC or local authority having jurisdiction. The owner is solely responsible for maintaining the water spray system and the components therein so that it performs properly when required. The equipment presented in this bulletin is to be installed in accordance with the latest publication standards of NFPA or other similar organizations and also with the provision of government codes or ordinances wherever applicable. The information provided by us is to the best of our knowledge and belief, and are general guidelines only. Site handling and installation control is beyond our reach. Hence we give no guarantee for result and take no liability for damages, loss or penalties whatsoever, resulting from our suggestion, information, recommendation or damages due to our product.

**3 NEW SYSTEM :**



Fig : Spherical Multi-Nozzle Fire Extinguisher

Interior structure firefighting is now becoming more challenging and dangerous than in the past. Many new buildings, such as commercial centers, galleries, exhibition halls and warehouses, are becoming bigger and more complex. These buildings have big open indoor areas containing extensive volumes of combustion gas once a fire occurs. Also, the extensive use of new materials for building construction and contents can result in increasing smoke productions and more rapid flame development once they ignite. The use of new construction technologies, such as the widespread installation of double-glazed, energy-efficient windows, that allow hot smoke to be contained in the room for an extended period, also adds to the challenges for firefighting. Conventionally, water has been used as an efficient agent in controlling a fire and minimizing its spread. There are two traditional fire-attack methods, namely, direct and indirect

attack. In the direct attack (DIR), water is applied to the base of the fire using either a straight stream or narrow-angle fog as firefighters advance into the immediate fire area. In the indirect attack, water is applied to hot surfaces to produce steam to smother the flames. The direct attack method is preferred for an incipient or growing unobstructed fire, whereas an indirect attack is preferred for a post-flashover/fully developed fire. However, for a wide range of interior fires, these approaches may not be effective. Some of these fire scenarios where these approaches are not effective include.

#### **4 PIPING SYSTEM :**



Fig : Flexible braided hoses pipe

Flexible braided hoses for gas, oil, steam, compressed air and oxygen service are ideal for applications requiring a high degree of flexibility with tightness and protection against bursting. They are used in piping systems to neutralize problems caused by vibration, thermal expansion, piping alignment and to accommodate motion. 8773 hoses are selected for use to accommodate angular, axial, offset, radial and random motions.

Braided hoses are not to be compressed or stretched, select a hose long enough to allow proper flexing when accommodating axial movements. They are capable of handling high working pressures. The maximum working pressure is determined by the service temperature. Standard 8773 flexible hoses are for use up to 750 degree F temperature service. 8773-H (High Temp Hoses), are available for use up to 1000 degree F gives the temperature service. There are various end types available, including nipple, flange, and lap joint (floating) flange and welded pipe ends. All combinations of end types lengths are available to be custom ordered to meet any application. Braided flexible connectors are available in. "through 12" nominal pipe sizes. Standard sizes 2" through 12" can be ordered with flanged ends. Screwed ends can be ordered up to 8".

#### **5. Rotating Nozzle :**

##### **5.1 Features and Benefits:**

1. High impact, rotating straight stream with 20° angle for intense cleaning action.
2. Heavy duty, long wearing ceramic nozzle and seat for exceptional life.
3. Rotating nozzle can be conveniently mounted in any position using 1/4" NPT connection.
4. Corrosion resistant brass construction.



Fig : Nozzle

##### **5.2 Selection:**

The design of this rotating nozzle with its zero degree stream means more efficient cleaning with less water. The 7616 rotating nozzle is available in a wide range of Standard nozzle sizes to meet your system requirements of pressure and flow. A convenient chart is provided to aid in the selection of the correct nozzle size. The nozzle size is machined into every nozzle next to the threaded port. Note that the minimum pressure to assure smooth rotation is 500 PSI. The maximum pressure for the 7616 series is 2300 PSI.

##### **5.3 Advantages:**

1. The system is spherical so the 3-D spraying of water is obtained.
2. This is very fast fire extinguishing process.
3. The water is directly come in contact with core fire.
4. Also, the flammable substance gets wet due to direct contact with it.
5. The cost is less compared to its efficiency.

##### **5.4 Disadvantages:**

1. The machine is required to put ball in the fire e. g- drone , crane.

2. The material required should have best thermal properties.

#### **6 CONCLUSIONS:**

The 3D water fog technique is not designed to replace the direct fire attack as it mainly aims to provide a 'safe' approach route to the fire, to improve and maintain tenable conditions for firefighters, and to prevent the likelihood of flashover and back draft.

Compared to traditional straight stream or narrow fog techniques, both experimental and analytical results show that proper use of a 3D water fog technique can have a better cooling effectiveness, generate less steam and lead to less disruption of the thermal balance in the smoke layer by using short discharges, fine droplets and wide spray angle.

The 3D water fog technique has demonstrated advantages in controlling steadily growing fires where the space can still be entered, but where the seat of the fire cannot be attacked directly. It has also been found effective for offensive attack to control flashover. However, there is not sufficient research to evaluate its capability for other fire scenarios, such as preventing the likelihood of back draft, and controlling fire threats in low visibility scenarios.

#### **7. REFERENCES :**

1. Cohn, B. M., "Plastics and Rubber," Fire Protection Handbook, 18th Edition, National Fire Protection Association, 1997
2. Fredericks, A. A., "Little Drops of Water: 50 Years Later, Part 2," Fire Engineering March 2000
3. Grimwood, P., "New Wave 3-D Water Fog Tactics: A Response to Direct Attack Advocates," Fire Engineering, October 2000
4. Scheffey, J. P., Siegmann, C. W., Toomey, T. A., "1994 Attack Team Workshop: Phase II –Full-Scale Offensive Fog Attack Tests," Naval Research Laboratory, NRL/MR/6180-97-7944, 1997
5. Grimwood, P., "Fog Attack," Hoffman, S., Ed., FMJ International Publications Ltd., Redhill, Surrey, UK, 1992.
6. Publisher: Tsong-Ming Lin